

RG10A(B2S)/BGEF
Control de serie



Producto certificado por:



CARACTERÍSTICAS

Modelo	LITE 26(09)N8-2	LITE 35(12)N8-2	LITE 52(18)N8-2	LITE 71(24)N8-2
Capacidad frigorífica	2,64 kW	3,52 kW	5,28 kW	7,03 kW
Consumo frío	800 W	1.300 W	1.550 W	2.420 W
Capacidad calorífica	2,93 kW	3,81 kW	5,57 kW	7,33 kW
Consumo calor	880 W	1.090 W	1.630 W	2.130 W
Clasificación ErP frío/calor	A++ / A+	A++ / A+	A++ / A+	A++ / A+
Caudal de aire (int.)	260/330/460 m ³ /h	450/490/570 m ³ /h	500/600/800 m ³ /h	610/770/1.090 m ³ /h
Presión sonora (int.)	21/25/32/37 dB(A)	21//24/37,5/40,5 dB(A)	20/31/37/41 dB(A)	21/34,50/37/46 dB(A)
Caudal de aire (ext.)	1.750 m ³ /h	1.750 m ³ /h	2.100 m ³ /h	3.500 m ³ /h
Presión sonora (ext.)	55 dB(A)	56 dB(A)	56 dB(A)	62 dB(A)
Alimentación	220-240 V / 1 / 50 Hz			
Cableado alimentación (ext.)	(2+T)x1,50 mm ²	(2+T)x1,50 mm ²	(2+T)x1,50 mm ²	(2+T)x2,50 mm ²
Cableado comunicación	(4+T)x1,50 mm ²	(4+T)x1,50 mm ²	(4+T)x1,50 mm ²	(4+T)x2,50 mm ²
Tuberías frigoríficas	Ø1/4" / Ø3/8"	Ø1/4" / Ø3/8"	Ø1/4" / Ø1/2"	Ø3/8" / Ø5/8"
Carga fábrica / Carga adicional	0,47 kg / 0,012 kg	0,52 kg / 0,012 kg	1,10 kg / 0,012 kg	1,45 kg / 0,024 kg
Longitud máx. tuberías	25 m	25 m	30 m	50 m
Desnivel máx.	10 m	10 m	20 m	25 m

ESQUEMA CONEXIONES

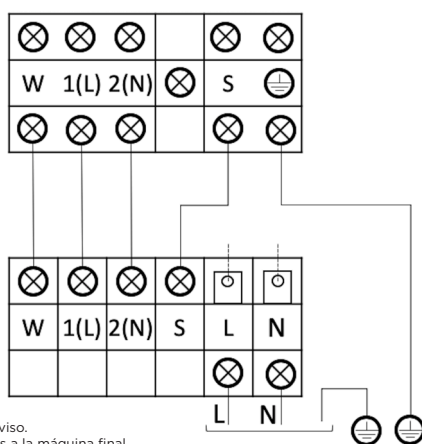

NOTAS:
 (1) Los datos y especificaciones presentes en esta ficha pueden variar sin previo aviso.
 (2) Las imágenes de esta ficha son de carácter orientativo, pudiendo ser diferentes a la máquina final.

DIMENSIONES Y PESO UNIDAD INTERIOR

Modelo	Peso	A	B	C
MAG2-09N8-2	7,7 kg	726 mm	291 mm	210 mm
MAG2-12N8-2	8,2 kg	835 mm	295 mm	208 mm
MAG2-18N8-2	11,2 kg	969 mm	320 mm	241 mm
MAG2-24N8-2	13,6 kg	1.083 mm	336 mm	244 mm

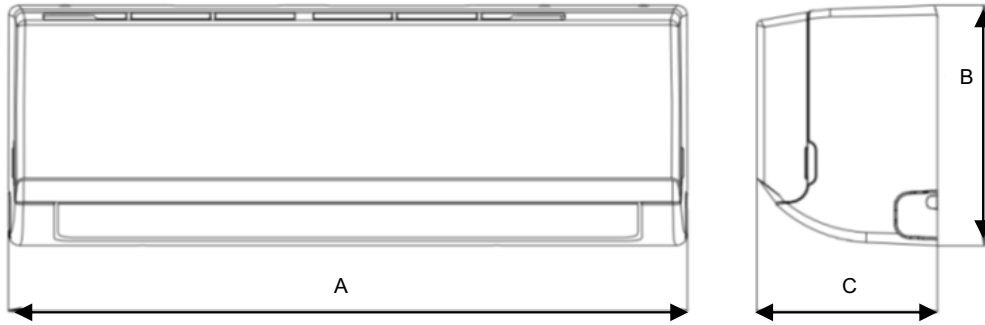

DIMENSIONES Y PESO UNIDAD EXTERIOR

Modelo	Peso	Ancho	Alto	Fondo
MOM-09N8D1-2	21,0 kg	720 mm	495 mm	270 mm
MOM-12N8D1-2	21,0 kg	720 mm	495 mm	270 mm
MOM-18N8D0-1	32,8 kg	805 mm	554 mm	330 mm
MOM-24N8D0-1	43,9 kg	890 mm	673 mm	342 mm

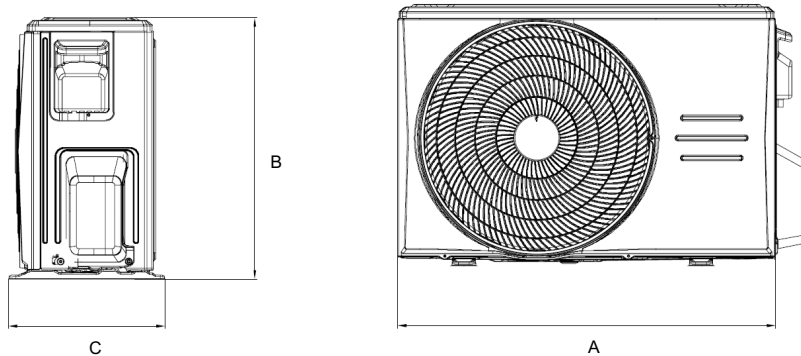

INSTALACIÓN

